

## BUNKER DISCHARGE MACHINE



## BUNKER DISCHARGE MACHINE FUNCTIONAL DESCRIPTION

WTW's Bunker Discharge Machine (BDM) is purpose-built to extract wet, cohesive, coarse, and abrasive non-free-flowing bulk materials from a wide range of storage types, including bunkers, hoppers, bins, silos, stockpiles, and dome-type storages. Equipped with rotating discharge arms, the BDM efficiently reclaims bulk material from bunker shelves and transfers it to a conveying system. The machine's self-propelled design enables automatic travel through tunnels beneath the stored material, ensuring seamless and reliable operation.

Available in a variety of configurations to suit diverse applications, the BDM's discharge system features six logarithmic-shaped arms for consistent and controlled material flow. These arms are bolted to a robust hub, secured with a shrink disk, and connected to the reducer's output shaft for optimal performance. Lined with wear-resistant plates, the discharge arms are engineered for extended durability, even when handling abrasive materials.

WTW's Bunker Discharge Machine sets the industry standard for reliability in continuous operation. With precision-engineered designs and proven performance, the BDM is the trusted solution for the toughest material handling challenges.



## WHO WE ARE

At WTW Americas, we lead the industry in designing precision-engineered, heavy-duty bulk material handling equipment. In partnership with **Gecos GmbH**, our German-engineered solutions deliver unmatched reliability and operational efficiency to industries like cement, power, mining, and environmental sectors, making us the trusted choice for advanced material handling challenges.



## BLOCK - TECHNICAL DATA

Discharge capacity 5,0 ... 3,500 t/h

Diametre of discharge wheel D1 (mm)	L1 (mm)	L1 (mm)	L3 (mm)	L4 (mm)	H1 (mm)	H2 (mm)	H3 (mm)
2000	350	1300	700	500	1000	200	600
2500	450	1600	820	600	1100	250	775
3000	700	1600	820	600	1100	300	775
3500	850	1800	910	700	1150	350	950
4000	1000	2000	1000	800	1200	400	1030
4500	1100	2400	1200	1000	1200	440	1030
5000	1150	2700	1400	1200	1200	500	1030

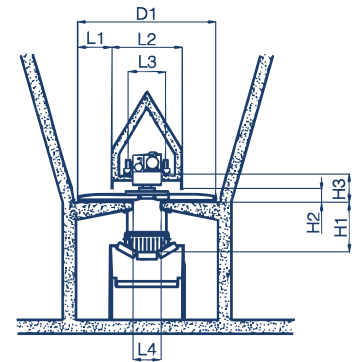

## LOW PROFILE - TECHNICAL DATA

Discharge capacity 2,5 ... 1,750 t/h

Diametre of discharge wheel D1 (mm)	L1 (mm)	L1 (mm)	L3 (mm)	L4 (mm)	H1 (mm)	H2 (mm)	H3 (mm)
2000	400	220	1500	250	1600	200	600
2500	450	240	1850	325	1650	250	650
3000	700	260	2200	400	1800	300	650
3500	800	280	2500	500	1900	350	700
4000	1000	300	2800	600	2000	400	750

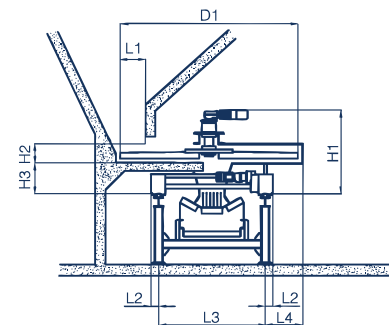

## INDUSTRIES OUR PRODUCTS ARE BUILT FOR

- GYPSUM
- CEMENT
- POWER
- ALTERNATIVE FUELS
- MINING
- CHEMICAL
- FOUNDRIES
- ENVIRONMENTAL PROTECTION
- SLUDGE & WASTE HANDLING

## MORE WTW AMERICAS PRODUCTS



**ROTARY DISCHARGE  
MACHINE**

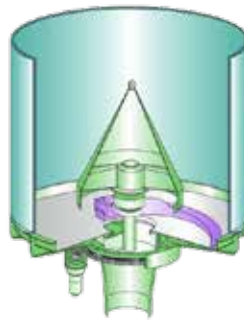

**SILO DISCHARGE  
MACHINE**

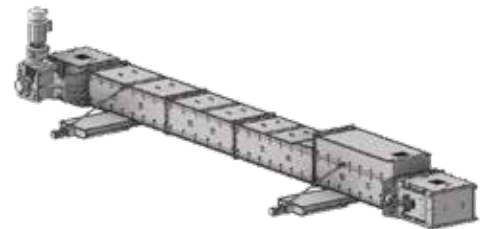

**TKF CHAIN  
CONVEYOR**

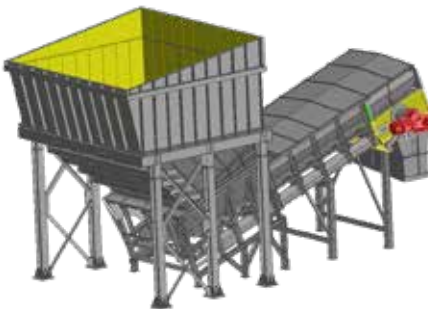

**TRUCK DISCHARGE  
MACHINE**



**SWEEPING  
AUGER**

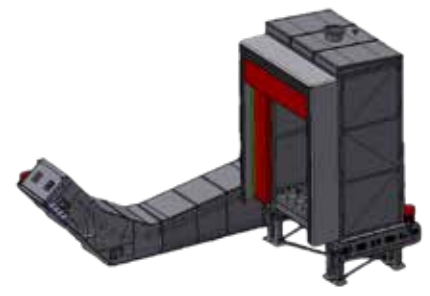

**TRAILER DOCKING  
STATION**

**YOUR BULK MATERIAL HANDLING EXPERTS!**

P.O. BOX 1536, PETERBOROUGH, ON CANADA • K9J 7H7