

## CHAIN CONVEYORS



## CHAIN CONVEYOR FUNCTIONAL DESCRIPTION

WTW's chain conveyors provide a fully enclosed conveying solution, ensuring dust containment and safe handling of hazardous, hot, elevated, or overhead materials. Designed for improved safety and efficiency, our self-cleaning chain conveyors operate in horizontal (TKF Chain Conveyor), inclined, and even vertical (SKF Chain Conveyor) configurations. Built for heavy-duty applications, they excel in transporting abrasive and cohesive materials across industries such as cement, mining, chemical, steel, gypsum, alternative fuels, and power.

Engineered for longevity, our chains are crafted from high-strength materials with precision-manufactured links, advanced hardening treatments, and superior fastening components. High-quality alloy steel connectors and pins undergo specialized processes to enhance durability and resistance to wear, ensuring a trouble-free, long-lasting system.

Available in dust-free, gas- or pressure-tight, and explosion-proof designs, WTW chain conveyors offer multiple discharge points for feeding surge hoppers. Whether handling sticky, high-temperature materials (up to 750°C), or highly abrasive substances, our chain conveyors deliver unmatched reliability and performance across demanding industries.

## WHO WE ARE

At WTW Americas, we lead the industry in designing precision-engineered, heavy-duty bulk material handling equipment. In partnership with **Gecos GmbH**, our German-engineered solutions deliver unmatched reliability and operational efficiency to industries like cement, power, mining, and environmental sectors, making us the trusted choice for advanced material handling challenges.

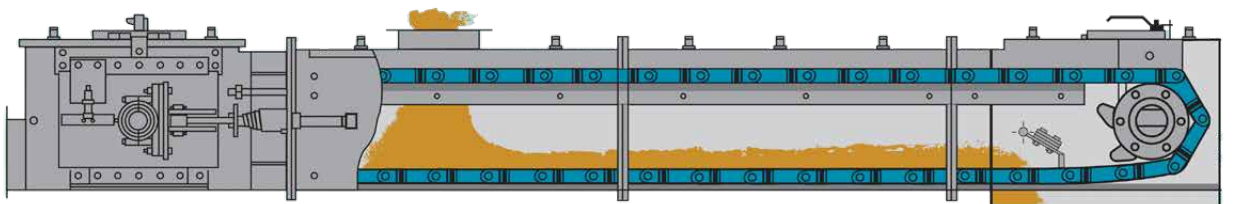
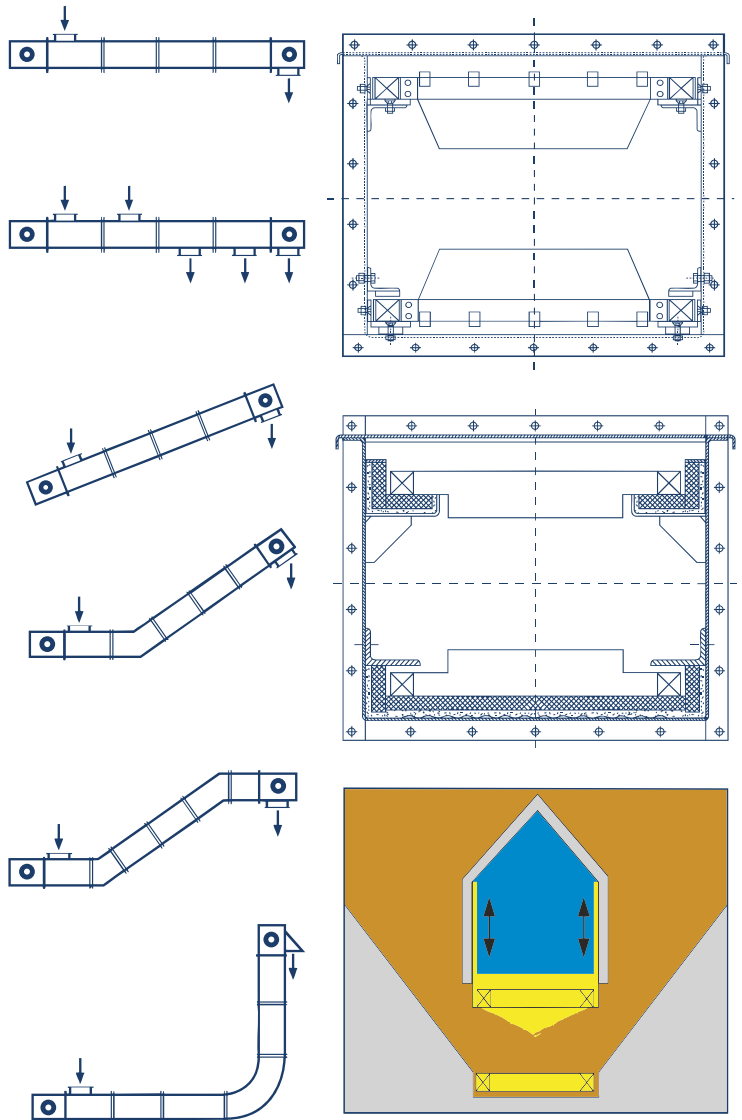

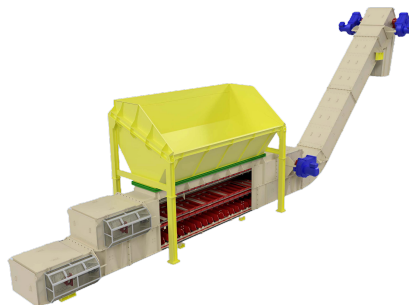
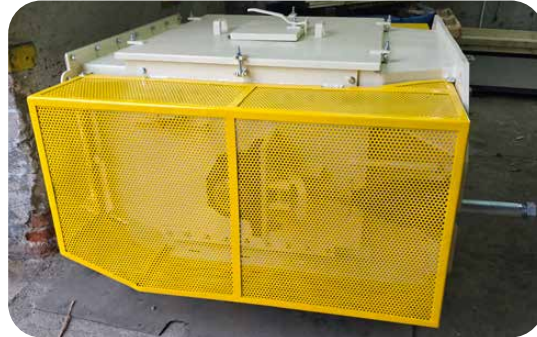

**SINGLE STRAND**

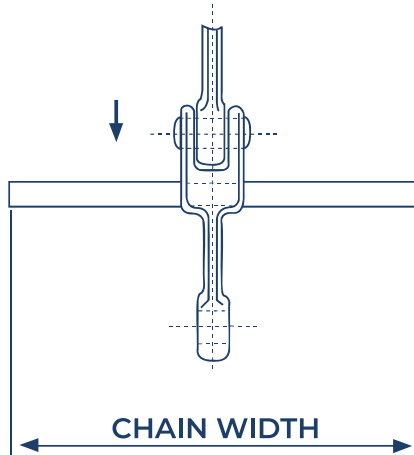

**DOUBLE STRAND**

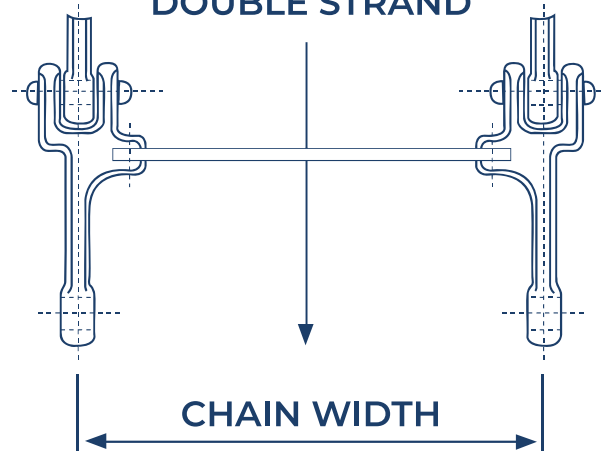

## METRIC

Chain Width (mm)	250	315	400	500	630	800	1000	1200	1400	1600	1800	2000
Nom. Capacity (m <sup>3</sup> /h)	30	50	80	125	175	285	400	550	675	800	925	1100

## IMPERIAL

Nom. Chain Width (in)	10	12	16	20	25	32	40	48	56	64	72	80
Nom. Capacity (ft <sup>3</sup> /h)	1060	1765	2825	4415	6180	10050	14100	19400	23850	28250	32650	38850

Capacities are based on horizontal conveying with a chain speed of .25 m/sec. (50 fpm).

## INDUSTRIES OUR PRODUCTS ARE BUILT FOR

- GYPSUM
- CEMENT
- POWER
- ALTERNATIVE FUELS
- MINING
- CHEMICAL
- FOUNDRIES
- ENVIRONMENTAL PROTECTION
- SLUDGE & WASTE HANDLING

## MORE WTW AMERICAS PRODUCTS

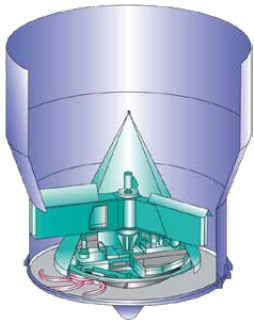

**ROTARY DISCHARGE  
MACHINE**

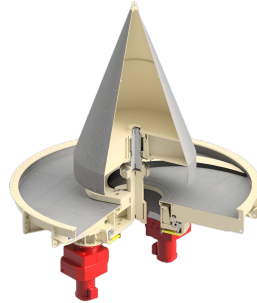

**SILO DISCHARGE  
MACHINE**

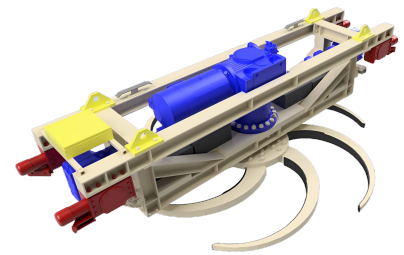

**BUNKER DISCHARGE  
MACHINE**

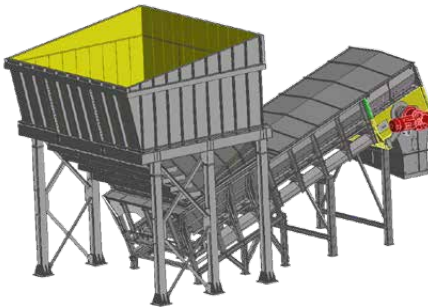

**TRUCK DISCHARGE  
MACHINE**

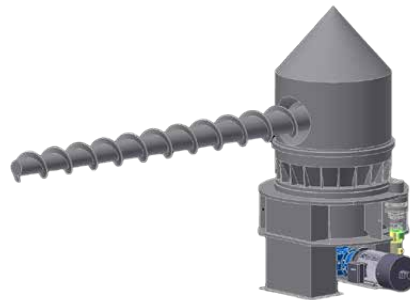

**SWEEPING  
AUGER**

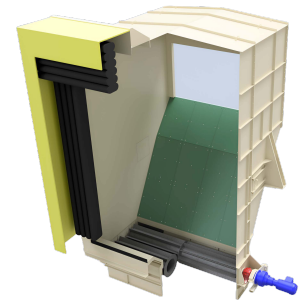

**TRAILER DOCKING  
STATION**

**YOUR BULK MATERIAL HANDLING EXPERTS!**

P.O. BOX 1536, PETERBOROUGH, ON CANADA • K9J 7H7